

DATAKOM



DM936 C13 DUPLEXER

OPTICAL CIRCULATOR

DATASHEET

DM936

C13 DUPLEXER LC/UPC

OPTICAL CIRCULATOR SOLUTION TO TRANSFORM UNIDIRECTIONAL OPTICAL LINKS INTO BIDIRECTIONAL

The DM936 C13 DUPLEXER is the perfect solution for transforming two-fiber links into single-fiber links, without the need to replace optical transceivers.

Operating in the 1260 nm to 1340 nm band, this passive optical circulator offers low insertion loss and optimizes fiber utilization by releasing one fiber out of two with minimal investment. It has an LGX format, allowing fixation in 19" racks, use the MA-26 accessory.

Bidirectional transceivers use different wavelengths for the uplink and downlink signals, resulting in two distinct transceiver codes at each end. When you want to optimize existing installations that use links from two fibers to a single fiber, the DM936 C13 is essential as it adjusts the coupling of signals from two to a single fiber.

In addition, Datacom also offers conventional bidirectional transceivers to complement this solution.

- Transforms links of two fibers into a single fiber
- Passive equipment, no power supply required
- Operates in the 1260-1340 nm band with low insertion loss
- Optimizes existing installations
- LGX format, compatible with 19" rack via MA-26 strip
- Compatible with different technologies: SFP, SFP+, QSFP+ and QSFP28.

APPLICATION

The operation of the DM936 C13 is simple and efficient: the transmit signal (TX) from the transceiver enters port 1 and is directed to port 2, which corresponds to the link. The signal received on the link on port 2 is then redirected to port 3, where it is received by the transceiver. For this configuration to work properly, it is necessary to install a circulator at each end of the link.

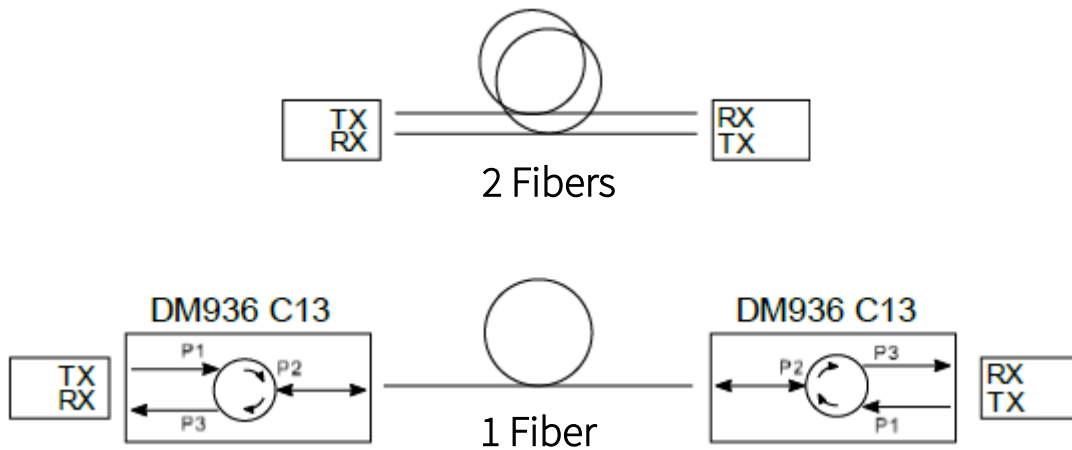

The figure above demonstrates the difference between the original configuration, using two fibers, and the optimization provided by the DM936 C13, where only one fiber is used to transmit and receive the signals. This feature is especially useful for freeing up one of the fibers in systems where both are initially needed, allowing for more efficient and cost-effective use of existing infrastructure. Migrating to use the DM936 C13 requires re-evaluation of the available power budget. Introducing the two DM936 C13 units into the link causes a total maximum loss of up to 2.2dB point-to-point.

In addition, the DM936 C13 preserves the original transceivers, maintaining system integrity and reducing costs associated with equipment replacement. This optical circulator is an effective solution for extending the capacity of optical networks while maximizing the return on investment in fiber optic infrastructure.



OPTICAL FEATURES

Item	Description
Function	Optical circulator
Operating Wavelength	1260 nm to 1340 nm
P1->P2 and P2->P3 Insertion Loss	< 1.1dB per element or < 2.2dB point-to-point
PMD	≤ 0.1 ps
Directivity	>50 dB
Loss of return	>50 dB
Power capacity	27 dBm on port 2
Connector Type	LC/UPC
Fiber Type	G.652

PHYSICAL AND ENVIRONMENTAL SPECIFICATIONS

Item	Description
Height	29 mm
Width (product body)	102 mm
Width (front panel)	129 mm
Depth	130 mm
Liquid weight	0.25kg
Operating Temperature	-5°C a 75°C
Storage Temperature	-40°C a 85°C

ORDERING INFORMATION

Product / Code	Description	Photo
<p>DM936 C13 DUPLEXER LC/UPC 815.4541.xx</p>	<p>DM936 - Passive duplexer module for signals in the range of 1260nm to 1340nm. It allows transport over single fiber using two-fiber transceivers, without performing wavelength multiplexing, but rather by optical circulation technique (A-side and B-side transceivers can be equal). Signals from the transceiver's TX port are transmitted to the LINE port. Signals received by the LINE port are transmitted to the transceiver's RX. Low insertion loss, less than 1.1dB per circulator port, equals a maximum of 2.2dB point-to-point on the link. LC/UPC connectors. Use with the MA-26 adapter.</p>	
<p>MA-26 800.5203.xx</p>	<p>Mechanical adapter for installation of up to 3 units of the DM936 MUX/DEMUX/DUPLEXER. Ready for installation in 19" rack. (PN only of the adapter ruler, does not come with DM936 multiplexers, purchased separately)</p>	

DATAKOM

Rua América, 1000 | 92990-000 | Eldorado do Sul | RS | Brazil
+55 51 3933 3000
sales@datacom.com.br